



RICCI

rencontres internationales
de la culture · de la connaissance
et de l'immersif

14, 15 et 16 octobre 2024
ÉPINAL



[CORRESPONDANCEZ
DIGITALES]



Conférence - « Comment animer et développer un projet numérique et immersif ? Quelques bonnes pratiques » |



La Région
Grand Est



Camille PEREIRA

Directrice culturelle, Scènes et territoires avec le collectif Kinorev



Cyrielle TISSANDIER

Responsable de production, Pôle AADN



**Stéphanie BAUNET
KLEIN**

*chargée de projets
culturels et de médiation,
Département éducatif et
culturel des musées de
Strasbourg*



Stéphane POTIER

*Architecte DPLG, Inventive
Studio*



Bénédicte HANOT

*Directrice de la Culture et
de l'Animation du
territoire, Communauté
d'agglomération d'Epinal*



Marc GENATIO

*Chef de Projet Micro Folie,
Communauté d'agglomération
d'Epinal*

Présentation de l'écosystème Epinal » |



Camille PEREIRA

Directrice culturelle, Scènes et territoires avec le collectif Kinorev



La Région
Grand Est

ESPACES PUBLICS - Développer des projets culturels dans l'espace rural



DEPUIS 1997

scènes & territoires

Association créée il y a plus de 25 ans

D'une scène conventionnée multi-sites à une Convention
Pluriannuelle d'Objectifs multi-acteurs

Une démarche singulière : la culture se construit plutôt qu'elle ne
se décrète

Accompagnement technique et accompagnement à l'émergence



AU FIL DE LA SEILLE

2021-2025



L'aventure

Interpellation par la Fédération des Foyers Ruraux de Moselle

Préservation de l'environnement et de la mémoire

Projet participatif innovant

Echelle d'un espace naturel

KINOREV

Écritures croisées

Élargir les champs du cinéma et arts visuels
Complicités avec l'image
Histoires hors du commun
Équipe de truquistes, monteurs, décorateurs



VERS 2025



Un mois de fêtes

Scénario s'écrit au fil de l'eau

Fondements d'un récit qui touchera chaque habitant

Existence indépendante des projets locaux

Ancrage local

Expérience participative sur le temps long



ENJEUX

ET INDICATEURS



Fédérer les partenaires locaux
Multiplier les formes artistiques
Promouvoir les liens intergénérationnels
Place des arts vivants et du public dans notre société
Autres formes de narratologie



GALERIE



SCÈNES & TERRITOIRES



merci !



Présentation de l'écosystème Epinal » |



Cyrielle TISSANDIER

Responsable de production, Pôle
AADN

**PLANÉTARIUM - Créer des projets créatifs
et artistiques dans des planétariums**



RICCI

La Région
Grand Est

Créer des projets créatifs et artistiques dans des planétariums

CYRIELLE TISSANDIER

Responsable de production



Création : Cyrielle Tissandier - Planète(s) - Espace(s)

adn

ARTS
DU
SPECTACLE
ASSOCIATION

ASSEMBLÉE ARTISTIQUE DES DIVERSITÉS NUMÉRIQUES



UNE EXPERTISE SUR LE CHAMP DE LA CRÉATION IMMERSIVE

SENSITIVE ABSTRACTION - LAURENT CEDRINO



RÉSEAU DE COPRODUCTION SOUS DÔME

- 2012 ● 1ÈRE COLLABORATION
AVEC LE PLANETARIUM DE
VAULX-EN-VELIN
- 2017 ● 1ER APPEL À PROJETS
- 2018 ● OUVERTURE DU CONSORTIUM
DE 6 PARTENAIRES





COMITE D'UN FUTURE COMMUNAL - PLANETARIUM LESBOIS

LES ENJEUX

- Associer des partenaires issus de cultures artistiques pluridisciplinaires
- Mettre en commun nos compétences et moyens au service d'un projet de création



1 APPEL À PROJETS
PAR AN

LES RÉSIDENCES



1 ÉQUIPE LAUREATE

chaque année



7000 €

d'apport en co-production



20 JOURS

de résidence de création



7 CREATIONS

coproduites & accompagnées



40 CANDIDATURES

en moyenne

UN ÉVÈNEMENT POUR EXPÉRIMENTER LA CRÉATION SOUS DÔME



COOPÉRATION INTERNATIONALE

PROJET CHROMOSPHERE (EUROPE CREATIVE)

Un festival itinérant autour de la création immersive sous dôme mêlant workshops, projections, performances et action culturelle

Avec la Fondation Photon/Patchlab Digital Arts (Pologne),

ADAF Athens Digital Arts Festival (Grèce),

Live Performers Meeting (Italie), Fonix (Hongrie)

FULLDOME CREATIVE NETWORK

Reseau au Royaume Uni

Avec le Fulldome UK Festival et Cultvr Lab

FULLDOME FESTIVAL ACROSS EUROPE



Chromosphere

EXPERIENCE
THE EXTRAORDINARY
360° ADVENTURE



FLYER

PHOTON

ADAF

FONIX



Présentation de l'écosystème Epinal » |



Stéphanie BAUNET KLEIN

Chargée de projets culturels et de médiation, Département éducatif et culturel des musées de Strasbourg



Stéphane POTIER

Architecte DPLG, Inventive Studio

MUSÉES - Le parcours Le Numérique à l'Oeuvre



La Région
Grand Est

LE NUMÉRIQUE À L'ŒUVRE

Vivez des expériences
immersives au musée !

Musée de l'Œuvre
Notre-Dame /
Arts du Moyen Âge

[MUSEE-LEOEUVE.COM](https://www.musee-loeuvre.com)

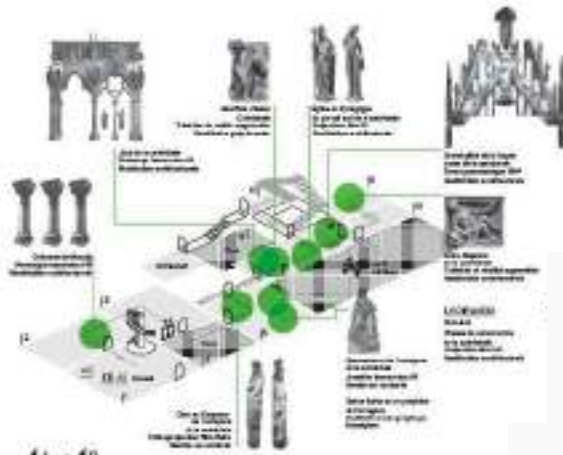

De roman au gothique

- | | | | | | | | | | | | | | | | | | | | | | | | | | | | | | | | | | | | | | | | | | | | | | | | | | | | | | | | | | | | | | | | | | | | | | | | | | | | | | | | | | | | | | | | | | | | | | | | | | | | |
|-------------------------|----------------------|--------------|-----------------|---------------|----------------|------------------|------------|----------|------------|---------|--------------|----------------|--------------|---------------|---------------|------------|-------------|------------|--------------|--------------|--------------|--------------|--------------|--------------|--------------|--------------|--------------|--------------|--------------|--------------|--------------|--------------|--------------|--------------|--------------|--------------|--------------|--------------|--------------|--------------|--------------|--------------|--------------|--------------|--------------|--------------|--------------|--------------|--------------|--------------|--------------|--------------|--------------|--------------|--------------|--------------|--------------|--------------|--------------|--------------|--------------|--------------|--------------|--------------|--------------|--------------|--------------|--------------|--------------|--------------|--------------|--------------|--------------|--------------|--------------|--------------|--------------|--------------|--------------|--------------|--------------|--------------|--------------|--------------|--------------|--------------|--------------|--------------|--------------|--------------|--------------|--------------|--------------|--------------|--------------|--------------|--------------|--------------|---------------|
| 1. Arcs en plein cintre | 2. Colonnes engagées | 3. Triforium | 4. Soubassement | 5. Contrefort | 6. Arc-boutant | 7. Voute ogivale | 8. Clocher | 9. Chœur | 10. Abside | 11. Nef | 12. Transept | 13. Collatéral | 14. Chapelle | 15. Sacristie | 16. Vestibule | 17. Porche | 18. Portail | 19. Tympan | 20. Tympanon | 21. Tympanon | 22. Tympanon | 23. Tympanon | 24. Tympanon | 25. Tympanon | 26. Tympanon | 27. Tympanon | 28. Tympanon | 29. Tympanon | 30. Tympanon | 31. Tympanon | 32. Tympanon | 33. Tympanon | 34. Tympanon | 35. Tympanon | 36. Tympanon | 37. Tympanon | 38. Tympanon | 39. Tympanon | 40. Tympanon | 41. Tympanon | 42. Tympanon | 43. Tympanon | 44. Tympanon | 45. Tympanon | 46. Tympanon | 47. Tympanon | 48. Tympanon | 49. Tympanon | 50. Tympanon | 51. Tympanon | 52. Tympanon | 53. Tympanon | 54. Tympanon | 55. Tympanon | 56. Tympanon | 57. Tympanon | 58. Tympanon | 59. Tympanon | 60. Tympanon | 61. Tympanon | 62. Tympanon | 63. Tympanon | 64. Tympanon | 65. Tympanon | 66. Tympanon | 67. Tympanon | 68. Tympanon | 69. Tympanon | 70. Tympanon | 71. Tympanon | 72. Tympanon | 73. Tympanon | 74. Tympanon | 75. Tympanon | 76. Tympanon | 77. Tympanon | 78. Tympanon | 79. Tympanon | 80. Tympanon | 81. Tympanon | 82. Tympanon | 83. Tympanon | 84. Tympanon | 85. Tympanon | 86. Tympanon | 87. Tympanon | 88. Tympanon | 89. Tympanon | 90. Tympanon | 91. Tympanon | 92. Tympanon | 93. Tympanon | 94. Tympanon | 95. Tympanon | 96. Tympanon | 97. Tympanon | 98. Tympanon | 99. Tympanon | 100. Tympanon |
|-------------------------|----------------------|--------------|-----------------|---------------|----------------|------------------|------------|----------|------------|---------|--------------|----------------|--------------|---------------|---------------|------------|-------------|------------|--------------|--------------|--------------|--------------|--------------|--------------|--------------|--------------|--------------|--------------|--------------|--------------|--------------|--------------|--------------|--------------|--------------|--------------|--------------|--------------|--------------|--------------|--------------|--------------|--------------|--------------|--------------|--------------|--------------|--------------|--------------|--------------|--------------|--------------|--------------|--------------|--------------|--------------|--------------|--------------|--------------|--------------|--------------|--------------|--------------|--------------|--------------|--------------|--------------|--------------|--------------|--------------|--------------|--------------|--------------|--------------|--------------|--------------|--------------|--------------|--------------|--------------|--------------|--------------|--------------|--------------|--------------|--------------|--------------|--------------|--------------|--------------|--------------|--------------|--------------|--------------|--------------|--------------|--------------|--------------|---------------|

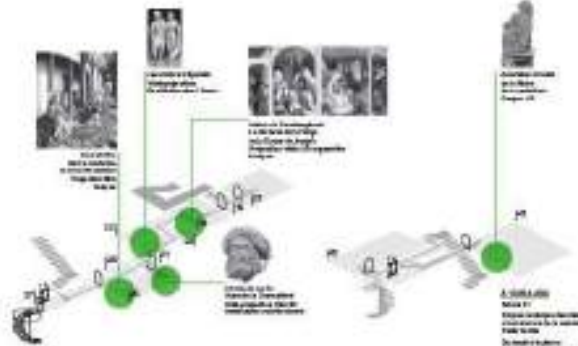

Le Haut Moyen Âge

1. Architecture carolingienne
2. Architecture ottonienne
3. Architecture romane
4. Architecture gothique

Deuxième Architecture

1. Architecture romane
2. Architecture gothique

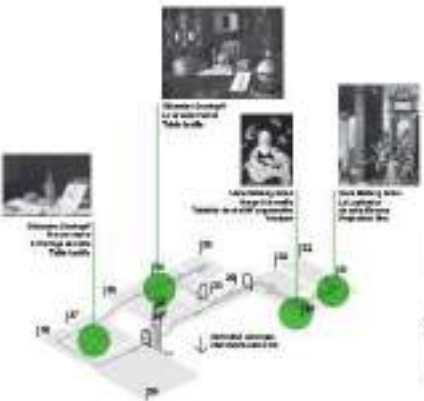

De la Renaissance à la fin du XVIe siècle

- | | | | | | | | | | | | | | | | | | | | | | | | | | | | | | | | | | | | | | | | | | | | | | | | | | | | | | | | | | | | | | | | | | | | | | | | | | | | | | | | | | | | | | | | | | | | | | | | | | | | |
|-----------------------------------|-----------------------------------|-----------------------------------|-----------------------------------|-----------------------------------|-----------------------------------|-----------------------------------|-----------------------------------|-----------------------------------|------------------------------------|------------------------------------|------------------------------------|------------------------------------|------------------------------------|------------------------------------|------------------------------------|------------------------------------|------------------------------------|------------------------------------|------------------------------------|------------------------------------|------------------------------------|------------------------------------|------------------------------------|------------------------------------|------------------------------------|------------------------------------|------------------------------------|------------------------------------|------------------------------------|------------------------------------|------------------------------------|------------------------------------|------------------------------------|------------------------------------|------------------------------------|------------------------------------|------------------------------------|------------------------------------|------------------------------------|------------------------------------|------------------------------------|------------------------------------|------------------------------------|------------------------------------|------------------------------------|------------------------------------|------------------------------------|------------------------------------|------------------------------------|------------------------------------|------------------------------------|------------------------------------|------------------------------------|------------------------------------|------------------------------------|------------------------------------|------------------------------------|------------------------------------|------------------------------------|------------------------------------|------------------------------------|------------------------------------|------------------------------------|------------------------------------|------------------------------------|------------------------------------|------------------------------------|------------------------------------|------------------------------------|------------------------------------|------------------------------------|------------------------------------|------------------------------------|------------------------------------|------------------------------------|------------------------------------|------------------------------------|------------------------------------|------------------------------------|------------------------------------|------------------------------------|------------------------------------|------------------------------------|------------------------------------|------------------------------------|------------------------------------|------------------------------------|------------------------------------|------------------------------------|------------------------------------|------------------------------------|------------------------------------|------------------------------------|------------------------------------|------------------------------------|------------------------------------|------------------------------------|------------------------------------|-------------------------------------|
| 1. Architecture de la Renaissance | 2. Architecture de la Renaissance | 3. Architecture de la Renaissance | 4. Architecture de la Renaissance | 5. Architecture de la Renaissance | 6. Architecture de la Renaissance | 7. Architecture de la Renaissance | 8. Architecture de la Renaissance | 9. Architecture de la Renaissance | 10. Architecture de la Renaissance | 11. Architecture de la Renaissance | 12. Architecture de la Renaissance | 13. Architecture de la Renaissance | 14. Architecture de la Renaissance | 15. Architecture de la Renaissance | 16. Architecture de la Renaissance | 17. Architecture de la Renaissance | 18. Architecture de la Renaissance | 19. Architecture de la Renaissance | 20. Architecture de la Renaissance | 21. Architecture de la Renaissance | 22. Architecture de la Renaissance | 23. Architecture de la Renaissance | 24. Architecture de la Renaissance | 25. Architecture de la Renaissance | 26. Architecture de la Renaissance | 27. Architecture de la Renaissance | 28. Architecture de la Renaissance | 29. Architecture de la Renaissance | 30. Architecture de la Renaissance | 31. Architecture de la Renaissance | 32. Architecture de la Renaissance | 33. Architecture de la Renaissance | 34. Architecture de la Renaissance | 35. Architecture de la Renaissance | 36. Architecture de la Renaissance | 37. Architecture de la Renaissance | 38. Architecture de la Renaissance | 39. Architecture de la Renaissance | 40. Architecture de la Renaissance | 41. Architecture de la Renaissance | 42. Architecture de la Renaissance | 43. Architecture de la Renaissance | 44. Architecture de la Renaissance | 45. Architecture de la Renaissance | 46. Architecture de la Renaissance | 47. Architecture de la Renaissance | 48. Architecture de la Renaissance | 49. Architecture de la Renaissance | 50. Architecture de la Renaissance | 51. Architecture de la Renaissance | 52. Architecture de la Renaissance | 53. Architecture de la Renaissance | 54. Architecture de la Renaissance | 55. Architecture de la Renaissance | 56. Architecture de la Renaissance | 57. Architecture de la Renaissance | 58. Architecture de la Renaissance | 59. Architecture de la Renaissance | 60. Architecture de la Renaissance | 61. Architecture de la Renaissance | 62. Architecture de la Renaissance | 63. Architecture de la Renaissance | 64. Architecture de la Renaissance | 65. Architecture de la Renaissance | 66. Architecture de la Renaissance | 67. Architecture de la Renaissance | 68. Architecture de la Renaissance | 69. Architecture de la Renaissance | 70. Architecture de la Renaissance | 71. Architecture de la Renaissance | 72. Architecture de la Renaissance | 73. Architecture de la Renaissance | 74. Architecture de la Renaissance | 75. Architecture de la Renaissance | 76. Architecture de la Renaissance | 77. Architecture de la Renaissance | 78. Architecture de la Renaissance | 79. Architecture de la Renaissance | 80. Architecture de la Renaissance | 81. Architecture de la Renaissance | 82. Architecture de la Renaissance | 83. Architecture de la Renaissance | 84. Architecture de la Renaissance | 85. Architecture de la Renaissance | 86. Architecture de la Renaissance | 87. Architecture de la Renaissance | 88. Architecture de la Renaissance | 89. Architecture de la Renaissance | 90. Architecture de la Renaissance | 91. Architecture de la Renaissance | 92. Architecture de la Renaissance | 93. Architecture de la Renaissance | 94. Architecture de la Renaissance | 95. Architecture de la Renaissance | 96. Architecture de la Renaissance | 97. Architecture de la Renaissance | 98. Architecture de la Renaissance | 99. Architecture de la Renaissance | 100. Architecture de la Renaissance |
|-----------------------------------|-----------------------------------|-----------------------------------|-----------------------------------|-----------------------------------|-----------------------------------|-----------------------------------|-----------------------------------|-----------------------------------|------------------------------------|------------------------------------|------------------------------------|------------------------------------|------------------------------------|------------------------------------|------------------------------------|------------------------------------|------------------------------------|------------------------------------|------------------------------------|------------------------------------|------------------------------------|------------------------------------|------------------------------------|------------------------------------|------------------------------------|------------------------------------|------------------------------------|------------------------------------|------------------------------------|------------------------------------|------------------------------------|------------------------------------|------------------------------------|------------------------------------|------------------------------------|------------------------------------|------------------------------------|------------------------------------|------------------------------------|------------------------------------|------------------------------------|------------------------------------|------------------------------------|------------------------------------|------------------------------------|------------------------------------|------------------------------------|------------------------------------|------------------------------------|------------------------------------|------------------------------------|------------------------------------|------------------------------------|------------------------------------|------------------------------------|------------------------------------|------------------------------------|------------------------------------|------------------------------------|------------------------------------|------------------------------------|------------------------------------|------------------------------------|------------------------------------|------------------------------------|------------------------------------|------------------------------------|------------------------------------|------------------------------------|------------------------------------|------------------------------------|------------------------------------|------------------------------------|------------------------------------|------------------------------------|------------------------------------|------------------------------------|------------------------------------|------------------------------------|------------------------------------|------------------------------------|------------------------------------|------------------------------------|------------------------------------|------------------------------------|------------------------------------|------------------------------------|------------------------------------|------------------------------------|------------------------------------|------------------------------------|------------------------------------|------------------------------------|------------------------------------|------------------------------------|------------------------------------|------------------------------------|------------------------------------|-------------------------------------|





Photos : K.Stober / M. Bertola / Musées de la Ville de Strasbourg / Inventiv



SYS #01
PERISCOPE

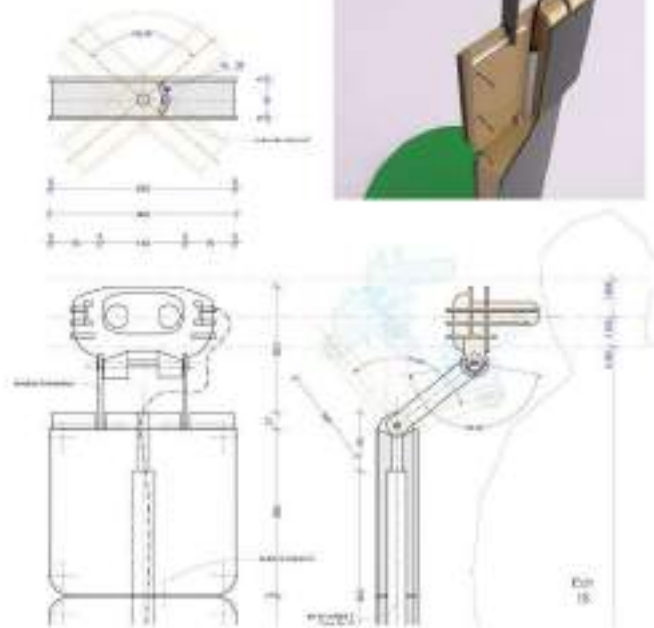





Prophète : anastylose



Sainte Barbe : anastylose



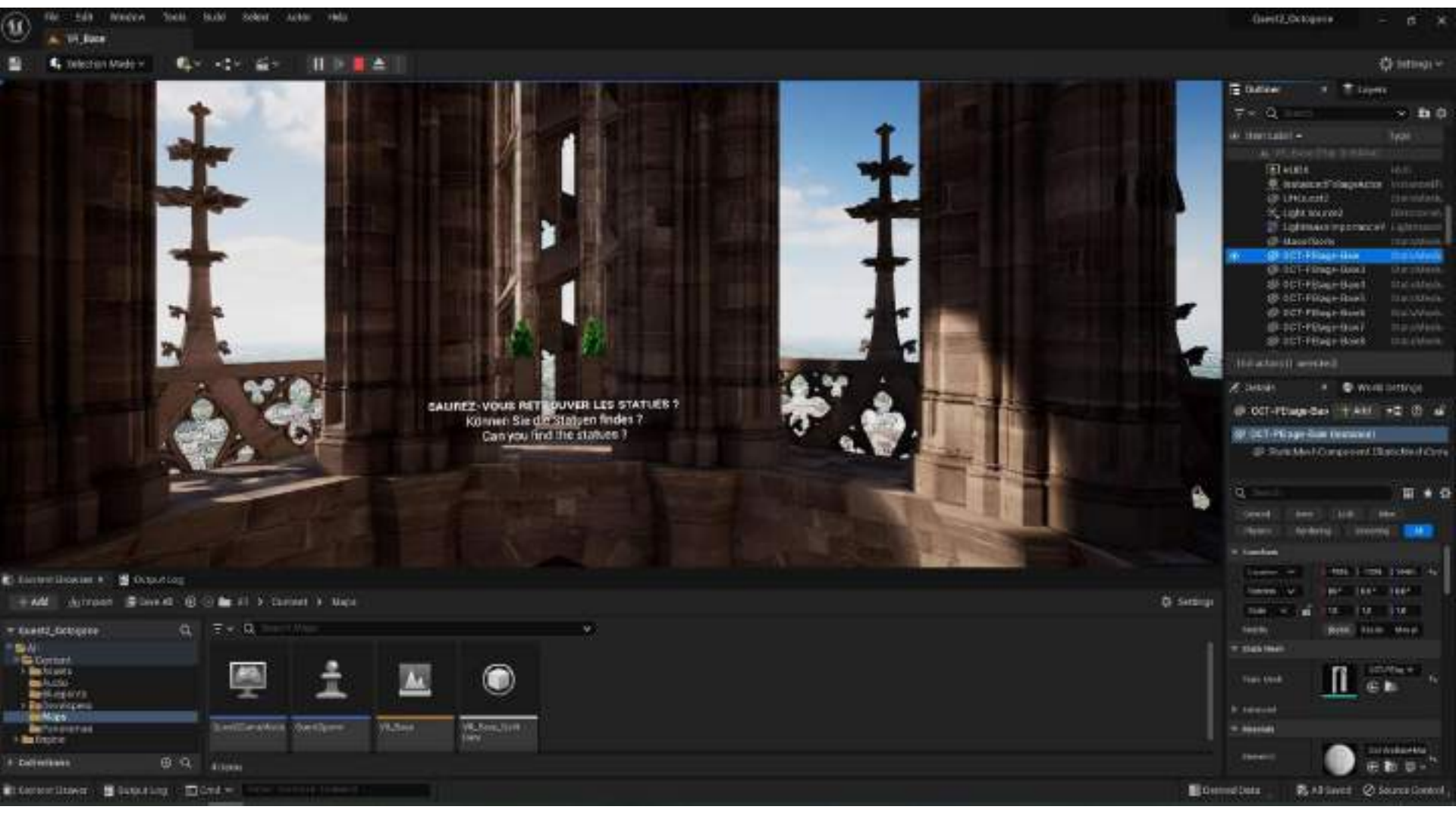



Autre état de polychromie

Le sacrifice d'Isaac - reconstitution partielle de la polychromie originale

(Illustration : Jean-Claude Bonaldi)

Hans Dillvert - Rapport d'étude - Jeu de la subtile - Musée de l'Évêché de Metz -
Juin 2005





Una capinazione in colubini
La scultura di Isacco

Questa scultura, intagliata in un unico blocco di marmo, rappresenta un momento di grande tensione e dolore. Il soggetto è la capinazione di Isacco, un episodio biblico in cui il padre, Isacco, è costretto a sacrificare il figlio. La scultura è divisa in due parti: la parte superiore mostra il padre che tiene il figlio in braccio, mentre la parte inferiore mostra il figlio che si inginocchia in preghiera. La scultura è un capolavoro dell'arte medievale, caratterizzata dalla sua forte espressività e dal suo uso del marmo.

Pictogrammi con i Minatori
Del Castello Isacco

Questo pannello illustra i pictogrammi utilizzati dai minatori del Castello Isacco. I pictogrammi sono simboli grafici che rappresentano le diverse attività e i pericoli presenti in una miniera. In questo caso, i pictogrammi sono utilizzati per indicare la presenza di gas tossici, di acqua, di fuoco e di altri pericoli. I pictogrammi sono un modo semplice e efficace per comunicare informazioni importanti in un ambiente di lavoro pericoloso.

Isacco
1200
Marmo

Prodotto da [illegibile]
Autore: [illegibile]
[illegibile]





12th - 15th C.
ÉGLISE SAINT-MARTIN
KIRCHE ST. MARTIN
ST. MARTIN CHURCH

12th - 15th C.
HOTEL LEVILLÉ (PRIZ)
HOTEL LEVILLÉ (PRIZ)

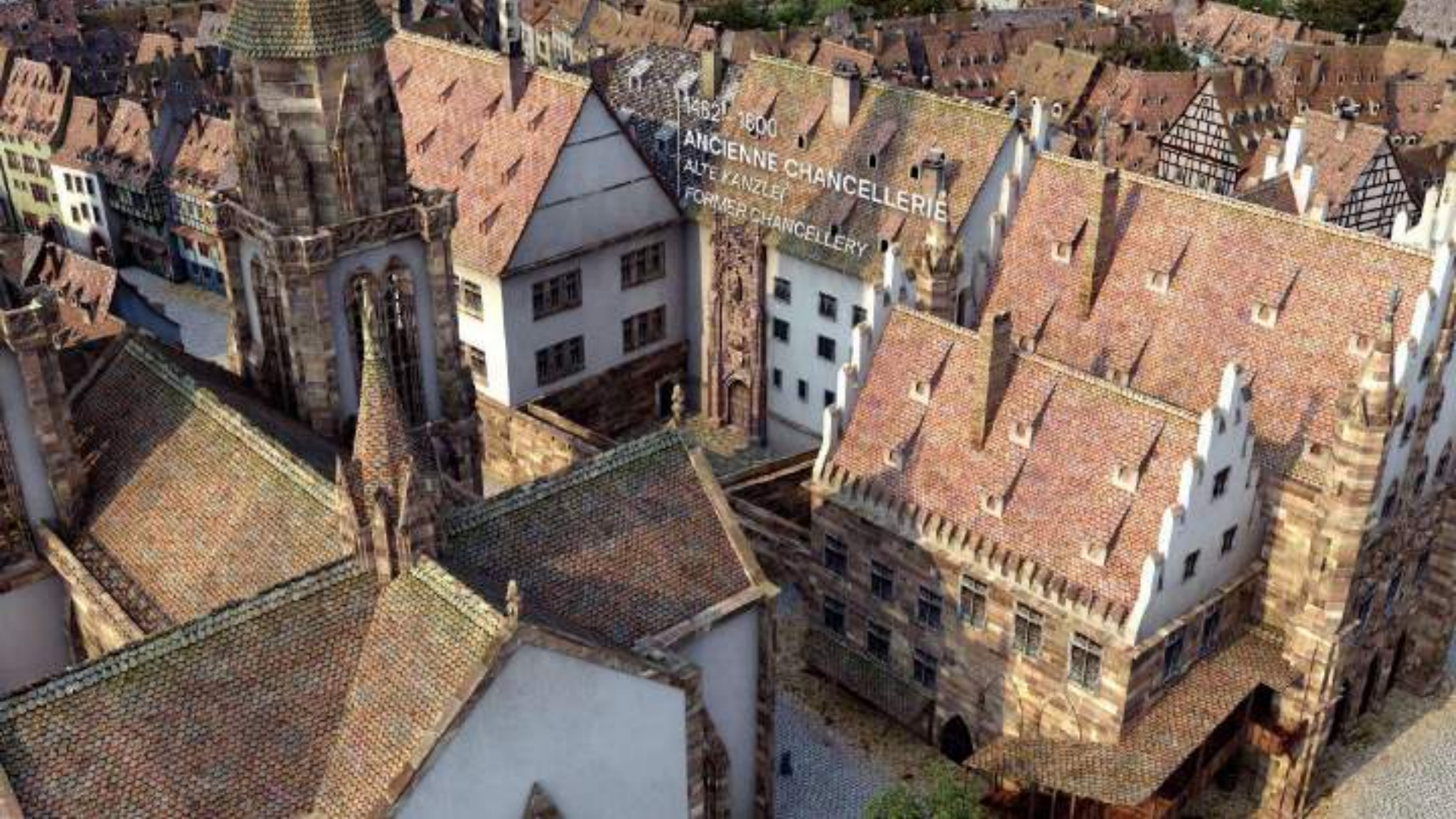

1462-1600

ANCIENNE CHANCELLERIE

ALTE KANZLEI

FORMER CHANCELLERY

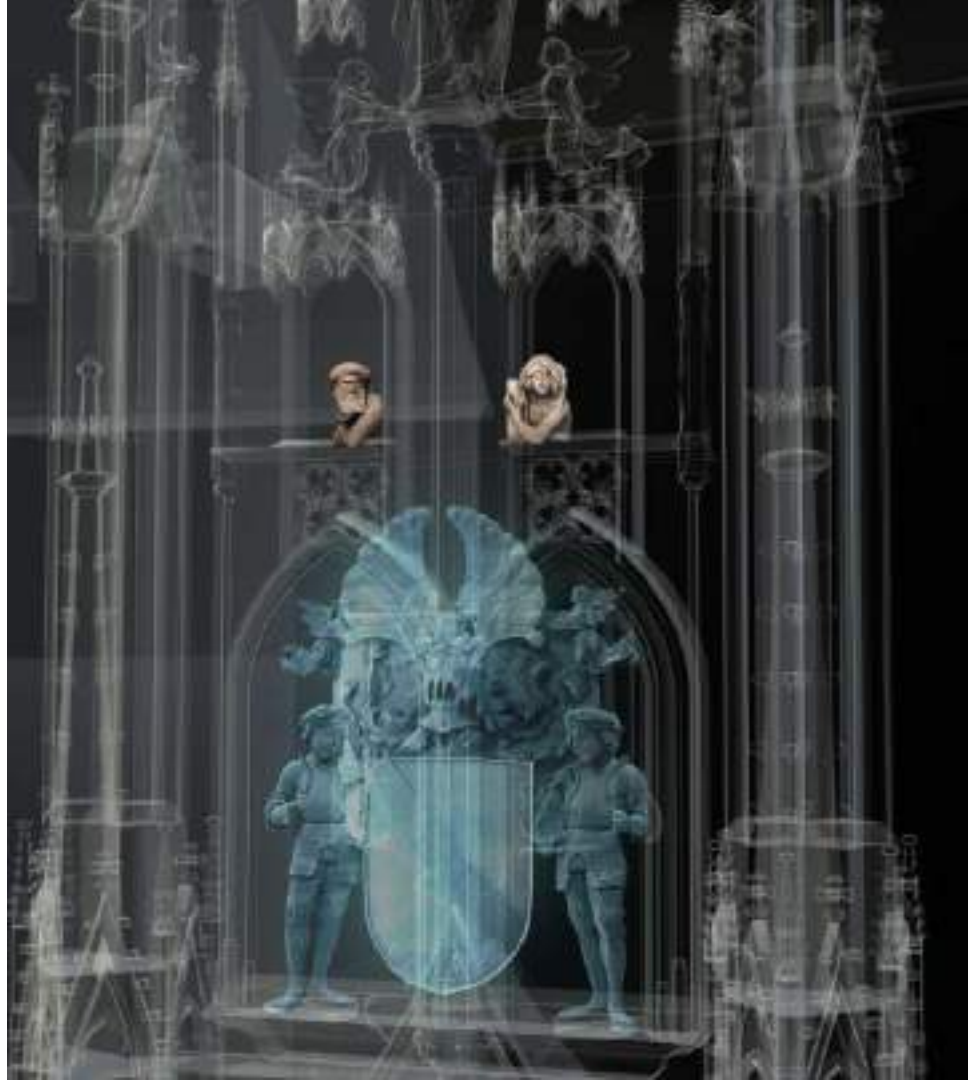
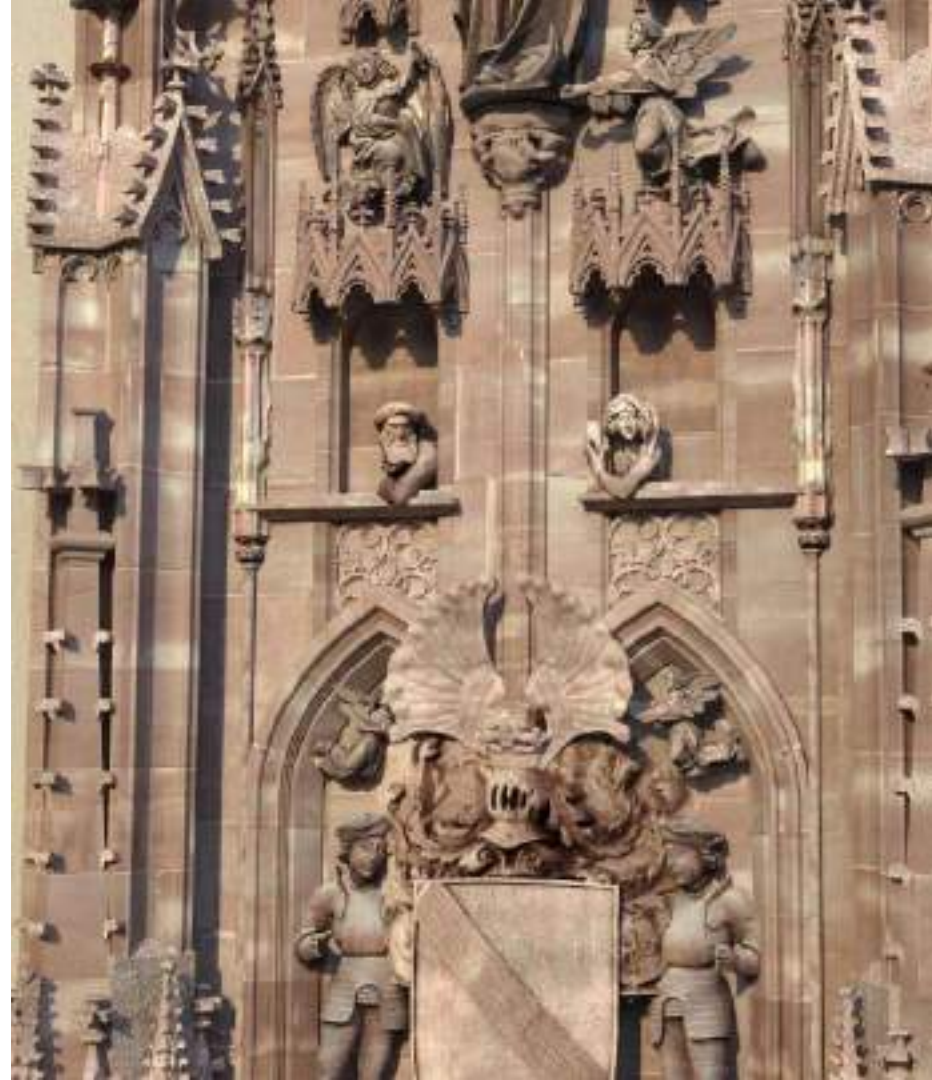



LES ARMOIRES DE LA VILLE,
TENUES PAR DES HOMMES EN ARMES

DAS STADTWAFFEN, GEHALTEN VON
BEWAFFNETEN MÄNNERN

THE CITY'S COAT OF ARMS HELD UP
BY ARMED MEN



Présentation de l'écosystème Epinal » |



La Région
Grand Est



Bénédicte HANOT

Directrice de la Culture et de
l'Animation du territoire,
Communauté d'agglomération
d'Epinal



Marc GENATIO

Chef de Projet Micro Folie,
Communauté d'agglomération
d'Epinal

**S'ancrer sur son territoire avec l'appui d'un
programme national**

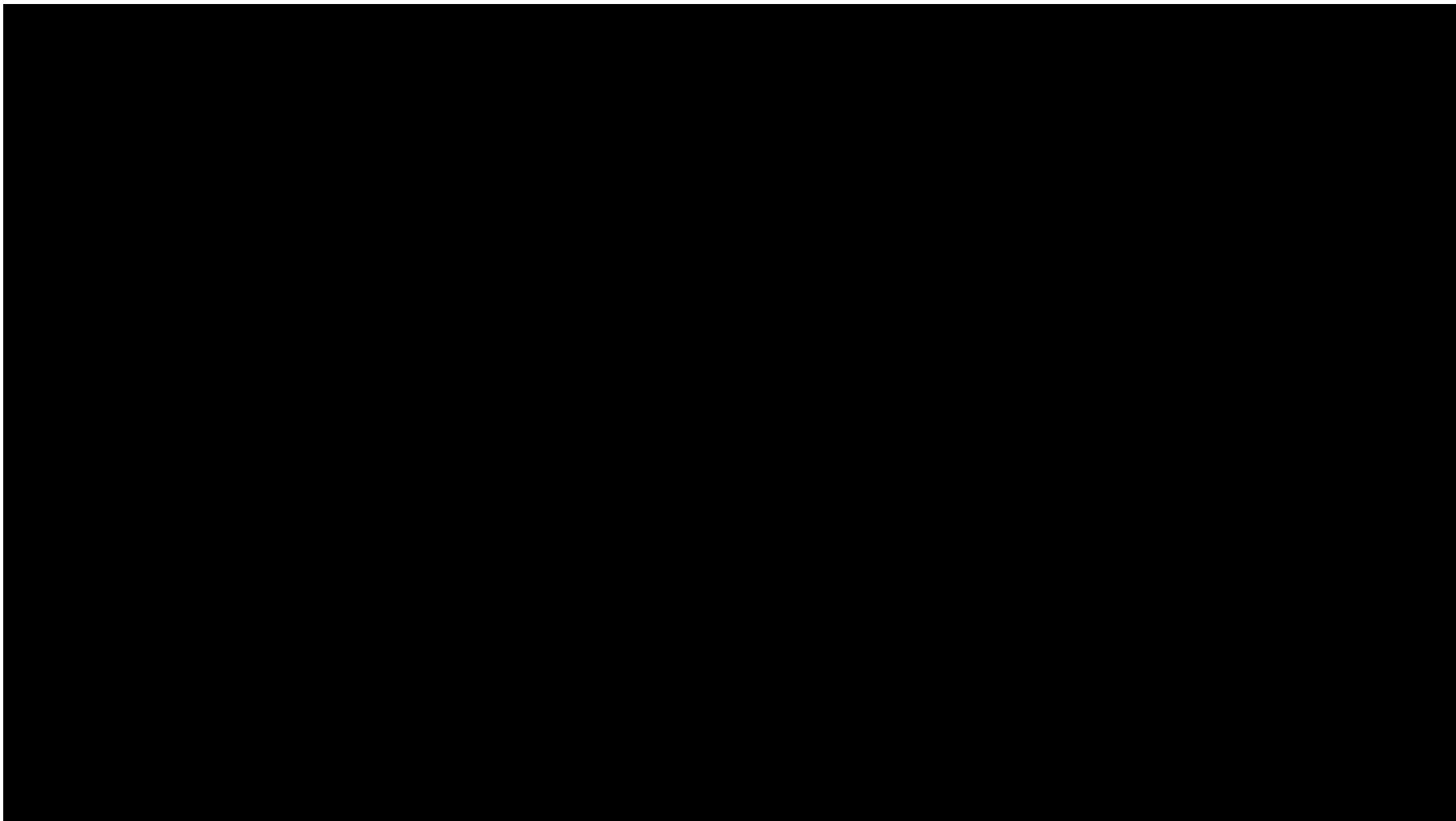

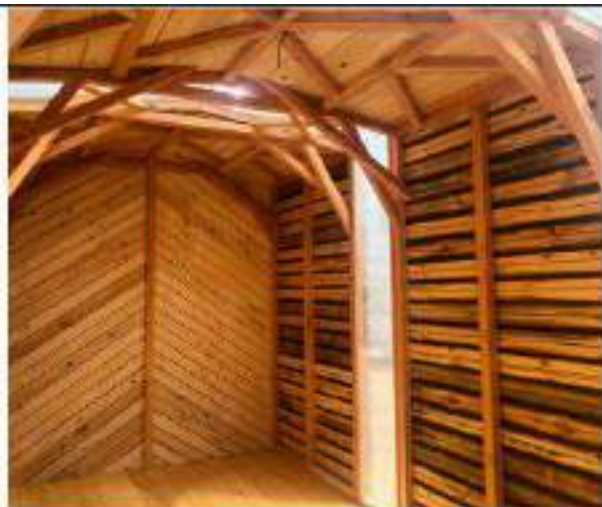











RICCI

rencontres internationales
de la culture · de la connaissance
et de l'immersif

14, 15 et 16 octobre 2024
ÉPINAL



[CORRESPONDANCE2
DIGITALES]

